



836

Landfill Compactor

Technical Specifications

Configurations and features may vary by region. Please consult your Cat® dealer for availability in your area.

Table of Contents

Specifications	2
Engine	2
Operating Specifications	2
Transmission	2
Hydraulic System – Lift	2
Hydraulic System – Steering	2
Service Refill Capacities	2
Air Conditioning System	3
Axles	3
Brakes	3
Sound Performance	3
Dimensions	4
Blade Selection	5
Wheels	5
Standard and Optional Equipment	6
Environmental Declaration	8

836 Landfill Compactor Specifications

Engine

Engine Model	Cat® C18	
Emissions	U.S. EPA Tier 4 Final, EU Stage V, Korea Stage V, and Japan 2014	
Rated Speed	1,900 rpm	
Net Power (SAE J1349:2011)	370 kW	496 hp
Net Power (ISO 9249:2007)	374 kW	502 hp
Gross Power (SAE J1995:2014)	419 kW	562 hp
Engine Power (ISO 14396:2002)	412 kW	553 hp
Emissions	Brazil MAR-1, equivalent to China Nonroad Stage III/U.S. EPA Tier 3/ EU Stage IIIA	
Rated Speed	1,900 rpm	
Net Power (SAE J1349:2011)	370 kW	496 hp
Net Power (ISO 9249:2007)	374 kW	502 hp
Gross Power (SAE J1995:2014)	419 kW	562 hp
Engine Power (ISO 14396:2002)	412 kW	553 hp
Peak Torque @ 1,400 rpm	3085 N·m	2,275 lbf-ft
Torque Rise	52%	
Bore	145 mm	5.71 in
Stroke	183 mm	7.2 in
Displacement	18.1 L	1,104.5 in ³
High Idle Speed	2120 rpm	
Low Idle Speed	750 rpm	
Maximum Altitude without Derating	2286 m	7,500 ft

- Net power advertised is the power available at the engine flywheel when the engine is equipped with a fan, air cleaner, clean emissions module and alternator.

Operating Specifications

Operating Weight (Tier 4 Final/Stage V)	56 275 kg	124,063 lb
Operating Weight (Tier 3/Stage IIIA equivalent)	55 939 kg	123,321 lb
Max Operating Weight (Tier 4 Final/Stage V)	57 318 kg	126,364 lb
Max Operating Weight (Tier 3/Stage IIIA equivalent)	56 982 kg	125,622 lb

Transmission

Transmission Type	Planetary – Powershift – ECPC	
Travel Speeds		
Direct Drive Forward 1	7.0 km/h	4.3 mph
Direct Drive Forward 2	12.6 km/h	7.8 mph
Direct Drive Reverse 1	7.4 km/h	4.6 mph
Direct Drive Reverse 2	13.2 km/h	8.2 mph

Hydraulic System – Lift

Lift System – Circuit	Flow Sharing Implement; Pilot Operated LS Valve w/EH	
Lift System – Pump	Variable displacement piston	
Max Flow @ 2,000 rpm	300 L/min	79 gal/min
Relief Valve Setting – Lift	29 000 kPa	4,206 psi
Cylinders, Double Acting: Lift, Bore, Stroke	137.9 mm × 1021 mm	5.5 in × 40.2 in
Pilot System	Variable displacement piston	
Pilot Relief Valve Setting	3800 kPa	551 psi

Hydraulic System – Steering

Steering System – Circuit	Flow Sharing Implement; Pilot, load sensing	
Steering System – Pump	Variable displacement piston	
Max Flow @ 2,000 rpm	300 L/min	79 gal/min
Relief Valve Setting – Steering	24 100 kPa	3,495 psi
Total Steering Angle	86°	
Steering Cycle Time (high idle)	3.9 sec	
Steering Cycle Time (low idle)	6.4 sec	

Service Refill Capacities

Fuel Tank	793 L	209 gal
Diesel Exhaust Fluid Tank	32.8 L	9 gal
Cooling Systems – Tier 4 Final/Stage V	151.5 L	40 gal
Cooling Systems – Tier3/Stage IIIA equivalent	141.1 L	37.2 gal
Engine Crankcase	60 L	16 gal
Transmission	83 L	21.9 gal
Differentials and Final Drives – front	186 L	49 gal
Differentials and Final Drives – rear	190 L	50 gal
Hydraulic System – implement/steering	175 L	46.2 gal
Hydraulic Tank Only	103 L	27.2 gal

- All nonroad Tier 4 Final/Stage V diesel engines are required to use:
 - Ultra low sulfur diesel (ULSD) fuels containing 15 ppm (mg/kg) for EPA and 10 ppm (mg/kg) for EU sulfur or less. Biodiesel blends up to B20 are acceptable when blended with 15 ppm (mg/kg) sulfur or less ULSD and when the biodiesel feedstock meets ASTM D7467 specifications.
 - Cat DEO-ULS™ or oils that meet the Cat ECF-3, API CJ-4, and ACEA E9 specifications are required.
 - Diesel exhaust fluid (DEF) that meets all requirements defined in ISO 22241-1:2006.

Air Conditioning System

The air conditioning system on this machine contains the fluorinated greenhouse gas refrigerant R134a (Global Warming Potential = 1430). The system contains 1.4 kg of refrigerant which has a CO₂ equivalent of 2.002 metric tonnes.

Axles

Front	Planetary – Fixed
Rear	Planetary – Oscillating
Oscillation Angle	±6°

Brakes

Service Brakes	Multi Disc Wet (Enclosed) 2 WHL
Parking Brake	Spring Applied, Hydraulic Released

Sound Performance

Tier 4 Final/EU Stage V, Korea Stage V, and Japan 2014

	Standard	Suppression
Operator Sound Level (ISO 6396:2008)	72 dB(A)	
Machine Sound Level (ISO 6395:2008)	111 dB(A)	109 dB(A)

Brazil MAR-1, equivalent to China Nonroad Stage III/Tier 3/
EU Stage IIIA

	Standard	Suppression
Operator Sound Level (ISO 6396:2008)	72 dB(A)	
Machine Sound Level (ISO 6395:2008)	112 dB(A)	110 dB(A)

- The operator sound pressure level was measured according to the test procedures and conditions specified in ISO 6396:2008. The measurements are conducted at 70% of the maximum engine cooling fan speed.
- Hearing protection may be needed when the machine is operated with a cab that is not properly maintained or when the doors or windows are open for extended periods or in a noisy environment.
- The machine sound power level was measured according to the test procedures and conditions specified in ISO 6395:2008. The measurements are conducted at 70% of the maximum engine cooling fan speed.

836 Landfill Compactor Specifications

Dimensions

All dimensions are approximate.

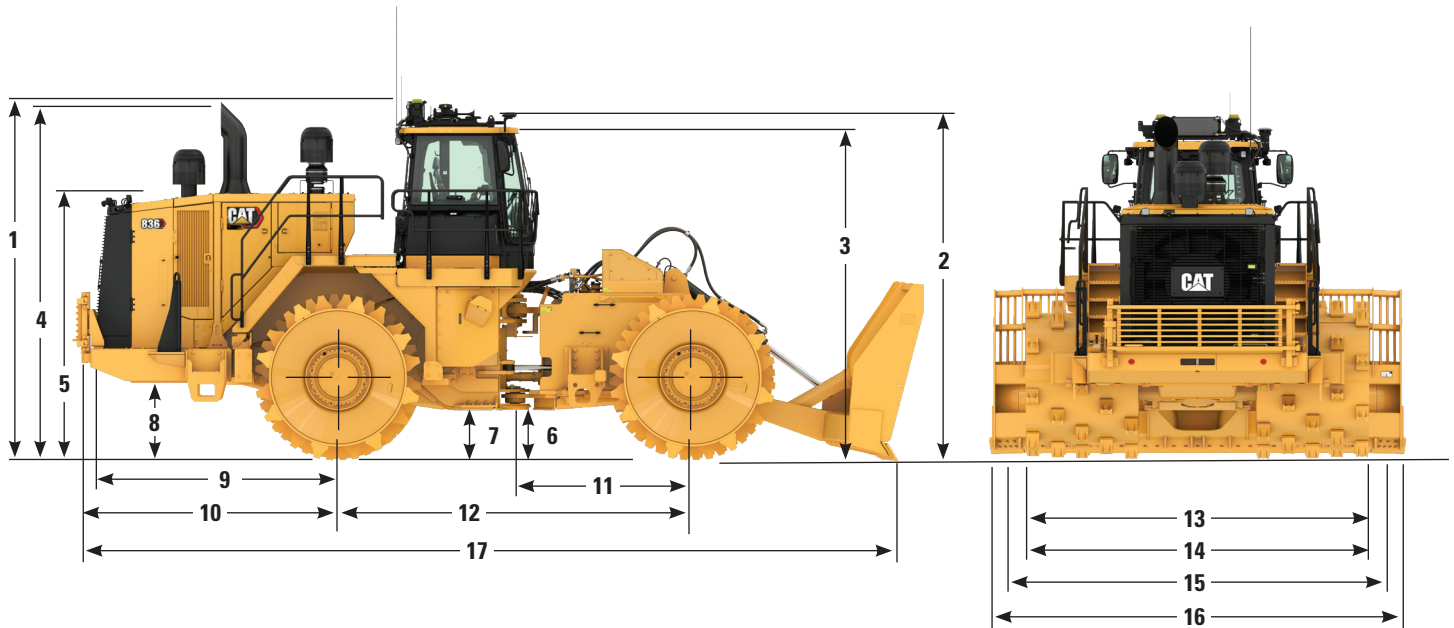

1	Height to Top of Beacon	4634 mm	15.2 ft
2	Height to Top of A/C Condenser	4626 mm	15.2 ft
3	Height to Top of Cab Roof	4285 mm	14.1 ft
4	Height to Top of Exhaust Pipe	4606 mm	15.1 ft
5	Height to Top of Hood	3430 mm	11.3 ft
6	Ground Clearance to Hitch	639 mm	2.1 ft
7	Ground Clearance to Transmission Guard	634 mm	2.1 ft
8	Ground Clearance to Bottom of Bumper	965 mm	3.2 ft
9	Centerline of Rear Axle to Bumper	3188 mm	10.5 ft
10	Centerline of Rear Axle to Rear Compactor Guard	3454 mm	11.3 ft
11	Centerline of Front Axle to Hitch	2275 mm	7.5 ft
12	Wheelbase	4550 mm	14.9 ft
13	Width Over Front Striker Bars	3930 mm	12.9 ft
14	Width Over Rear Striker Bars	3933 mm	12.9 ft
15	Width Over Platform	3196 mm	10.5 ft
16	Width Over Drums	4280 mm	14.0 ft
17	Overall Machine Length with Semi-U Blade	10 914 mm	35.8 ft

836 Landfill Compactor Specifications

Blade Selection

	Straight Blade		Semi U-blade		U-blade	
Capacity	19.8 m ³	25.9 yd ³	22.4 m ³	29.3 yd ³	25.7 m ³	33.6 yd ³
Overall Width	5193 mm	17.0 ft	5313 mm	17.4 ft	5290 mm	17.4 ft
Height	2260 mm	7.4 ft	2294 mm	7.5 ft	2204 mm	7.2 ft
Height of Cutting Edge	1125 mm	3.7 ft	1255 mm	4.1 ft	1255 mm	4.1 ft
Digging Depth	364 mm	1.2 ft	362 mm	1.2 ft	934 mm	3.1 ft
Ground Clearance	1730 mm	5.7 ft	1735 mm	5.7 ft	1198 mm	3.9 ft
Turning Radius – Outside Corner of Blade	8737 mm	28.7 ft	8823 mm	28.9 ft	8795 mm	28.8 ft
Turning Radius – Inside of Wheels	3635 mm	11.9 ft	3635 mm	11.9 ft	3635 mm	11.9 ft
Weight	3127 kg	6,894 lb	3612 kg	7,963 lb	3491 kg	7,696 lb
Total Operating Weight	55 792 kg	123,000 lb	56 275 kg	124,063 lb	56 149 kg	123,785 lb

Wheels

Combination Tips Weight (Group)	12 814 kg	28,250 lb
Plus Tips Weight (Group)	13 510 kg	29,784 lb
Paddle Tips Weight (Group)	12 350 kg	27,227 lb
Chopper Tips Weight (Group)	12 884 kg	28,404 lb
Diamond Tips Weight (Group)	14 814 kg	32,659 lb
Outside Diameter	2128 mm	83.8 in
Outside Diameter – Diamond	2140 mm	84.3 in
Drum Diameter	1770 mm	69.7 in
Drum Width	1400 mm	55.1 in
Feet per Row	8	
Feet per Wheel	40	
Replaceable	Weld On	
Width Over Drums	4280 mm	168.5 in
Tip Height	179 mm	7.0 in
Tip Height – Diamond	184 mm	7.25 in

836 Landfill Compactor Specifications

Standard and Optional Equipment

Standard and optional equipment may vary. Consult your Cat® dealer for details.

	Standard	Optional		Standard	Optional
POWERTRAIN			OPERATOR ENVIRONMENT		
Advanced productivity electronic control system (APECS)	✓		12V power port for mobile phone or laptop connection	✓	
Air-to-air aftercooler	✓		Cat Compact SBAS	✓	
Antifreeze, -50° C (-58° F)		✓	Air conditioner with roof-mounted condenser	✓	
Axles, Cat® locker (front and rear)	✓		Cab, sound-suppressed pressurized	✓	
Brakes, full hydraulic, enclosed, wet multiple disc service brakes	✓		Camera, rear vision	✓	
Cat clean emission module (Tier 4 Final/Stage V only)	✓		Fingertip shifting controls	✓	
Electro hydraulic parking brake	✓		Flip-up armrest	✓	
Electronic clutch pressure control (ECPC)	✓		Glass (window) – rubber-mounted glass	✓	
Engine, Cat C18 configured for two emissions options: Tier 4 Final/Stage V, Korea Stage V, and Japan 2014 or Tier 3/Stage IIIA equivalent	✓		Heater and defroster	✓	
Engine driven cooling fan – suction	✓		Horn group (trumpet)	✓	
Fuel priming pump (electric)	✓		Hydraulic controls – floor mounted	✓	
Fuel-to-air cooler	✓		Implement hydraulic lockout	✓	
Guard (3 piece) transmission	✓		Intermittent wipers (front and rear)	✓	
Ground level engine shutoff	✓		Instrumentation, gauges: diesel exhaust fluid (DEF) level (Tier 4 Final/Stage V only), engine coolant temperature, fuel level, hydraulic oil temperature, speedometer/tachometer, torque converter temperature	✓	
Heat shield, turbo, and exhaust manifold	✓		Instrumentation, warning indicators: action alert system – three categories, brake oil pressure, electrical system – low voltage, engine failure malfunction alert and action lamp, parking brake status	✓	
Heater, engine coolant, 120V		✓	Internal four-post rollover protective structure/falling objects protective structure (ROPS/FOPS)	✓	
Heater, engine coolant, 240V		✓	Lights, cab – standard or LED	✓	
Integrated braking	✓		Lunchbox and beverage holders	✓	
Muffler under hood (Tier 3/Stage IIIA equivalent only)	✓		Mirror, cab – standard or heated	✓	
Radiator, aluminum modular radiator (AMR)	✓		Mirrors, heated, rearview (externally mounted)	✓	
Separated cooling system	✓		Parking brake status	✓	
Starting aid (ether)	✓		Precleaner, cab powered	✓	
Throttle lock	✓		Radio, AM/FM/Aux/USB/Bluetooth		✓
Torque converter with lockup clutch (LUC)	✓		Radio, CB (ready)	✓	
Transmission, planetary with 2F/2R speed range control	✓		Radio ready for entertainment: antenna, speakers, converter (12V, 10-15 amp)	✓	
Turbine precleaner, engine air intake	✓		Seat belt with minder, retractable, 76 mm (3") wide	✓	
Underhood ventilation system	✓		Seat, cab – heated and ventilated	✓	
ELECTRICAL			Seat, Cat premium plus (leather)	✓	
Alarm, back-up	✓		Steering and Transmission Integrated Control (STIC™) control system with lockout	✓	
Alternator, 150 amp	✓		Transmission gear (indicator)	✓	
Batteries, maintenance-free (4-1,000 CCA)	✓		Vital Information Management System (VIMS™): graphical information display, external data port, customizable operator profiles, event indicator light on rear grill	✓	
Converter, 10-15 amp, 24V to 12V	✓		Wet-arm wipers/washers (front and rear): intermittent wipers (front and rear)	✓	
Electrical system, 24V	✓				
Ground level lockable master disconnect switch	✓				
Light, warning unswitched (LED strobe)	✓				
Lighting, access stairway	✓				
Lighting system halogen (front and rear)	✓				
Lighting system LED (front and rear)		✓			
Starter, electric (heavy duty)	✓				
Starter lockout (ground level)	✓				
Starting receptacle for emergency start	✓				
Transmission lockout (ground level)	✓				

836 Landfill Compactor Specifications

Standard and Optional Equipment (continued)

Standard and optional equipment may vary. Consult your Cat dealer for details.

	Standard	Optional		Standard	Optional
GUARDS			OTHER STANDARD EQUIPMENT (CONTINUED)		
Guards, axle (front and rear)	✓		Ecology drains for engine, radiator, transmission, hydraulic tank	✓	
Guard, cab window	✓		Electronic clutch pressure control and remote mounted pressure taps	✓	
Guards, crankcase and powertrain, hydraulically powered	✓		Engine, crankcase, 500 hour interval with CJ-4 oil	✓	
Guard, driveshaft	✓		Emergency platform egress	✓	
Guard, differential	✓		Fire suppression ready	✓	
Guards, rear fan and grill	✓		Fuel tank, 793 L (210 gal)	✓	
BLADES			Hitch, drawbar with pin	✓	
Dozer arrangement (no blade)	✓		Hoses, Cat XT™	✓	
Bulldozer blades		✓	Hydraulic, engine, and transmission oil coolers	✓	
FLUIDS			Hydraulic, steering and brake filtration/ screening system	✓	
Antifreeze, -50° C (-58° F)		✓	Oil change system, high speed	✓	
Antifreeze, premixed 50% concentration extended life (-34° C/-29° F)	✓		Oil sampling valves	✓	
TECHNOLOGY PRODUCTS			Stairways, fixed-L/R (rear access)	✓	
Product Link™ – Cellular	✓		Stairway, swingout (LH & RH)		✓
WHEELS AND CLEANER BARS			Steering, load sensing	✓	
Wheels and tips: wheel arrangements – 7" combination tips	✓		Total hydraulic filtration system	✓	
Wheels and tips: wheel arrangements – 7.25" diamond tips, 7" paddle tips, 7" plus tips and 7" chopper		✓	Vandalism protection caplocks	✓	
Striker bars	✓		Venturi stack	✓	
Striker bars with cleaner fingers		✓	SPECIAL ARRANGEMENTS		
OTHER STANDARD EQUIPMENT			Engine precleaners – single stage	✓	
Auto blade positioner (ABP)	✓		Engine precleaners – dual stage		✓
Demand fan/swing out (hydraulic reversible)	✓		Engine, sound suppression		✓
DEF tank fill gauge (Tier 4 Final/Stage V only)	✓		MISCELLANEOUS		
Doors, service access (locking)	✓		U.S. Film (Tier 4 Final/Stage V only)		✓
			EU certification (Tier 4 Final/Stage V only)		✓
			Plate – year of manufacture (Tier 3/Stage IIIA equivalent only)		✓

836 Landfill Compactor Environmental Declaration

The following information applies to the machine at the time of final manufacture as configured for sale in the regions covered in this document. The content of this declaration is valid as of the date issued; however, content related to machine features and specifications are subject to change without notice. For additional information, please see the machine's Operation and Maintenance Manual.

For more information on sustainability in action and our progress, please visit <https://www.caterpillar.com/en/company/sustainability>.

Engine

- The Cat® C18 engine is available in configurations that meet U.S. EPA Tier 4 Final, EU Stage V, Korea Stage V, and Japan 2014 or Brazil MAR-1 emission standards, equivalent to China Nonroad Stage III, U.S. EPA Tier 3 and EU Stage IIIA.
- Cat U.S. EPA Tier 4 Final, EU Stage V, Korea Stage V, and Japan 2014 diesel engines are required to use ULSD (ultra-low sulfur diesel fuel with 15 ppm of sulfur or less) or ULSD blended with the following lower-carbon intensity fuels up to:
 - ✓ 20% biodiesel FAME (fatty acid methyl ester)*
 - ✓ 100% renewable diesel, HVO (hydrotreated vegetable oil) and GTL (gas-to-liquid) fuels
- Cat engines meeting Brazil MAR-1 equivalent to China Nonroad Stage III, U.S. EPA Tier 3 and EU Stage IIIA, are compatible with diesel fuel blended with the following lower-carbon intensity fuels up to:
 - ✓ 100% biodiesel FAME (fatty acid methyl ester)**
 - ✓ 100% renewable diesel, HVO (hydrotreated vegetable oil) and GTL (gas-to-liquid) fuels

Refer to guidelines for successful application. Please consult your Cat dealer or “Caterpillar Machine Fluids Recommendations” (SEBU6250) for details.

**Engines with no aftertreatment devices can use higher blends, up to 100% biodiesel.*

***For use of blends higher than 20% biodiesel, consult your Cat dealer.*

Air Conditioning System

- The air conditioning system on this machine contains the fluorinated greenhouse gas refrigerant R134a (Global Warming Potential = 1430). The system contains 1.4 kg (3.1 lb) of refrigerant which has a CO₂ equivalent of 2.002 metric tonnes (2.206 tons).

Paint

- Based on best available knowledge, the maximum allowable concentration, measured in parts per million (PPM), of the following heavy metals in paint are:
 - Barium < 0.01%
 - Cadmium < 0.01%
 - Chromium < 0.01%
 - Lead < 0.01%

Sound Performance

Tier 4 Final, EU Stage V, Korea Stage V, and Japan 2014:

	Standard	Suppression
Operator Sound Level (ISO 6396:2008)		72 dB(A)
Machine Sound Level (ISO 6395:2008)	111 dB(A)	109 dB(A)

Brazil MAR-1 equivalent to China Nonroad Stage III, U.S. EPA Tier 3 and EU Stage IIIA:

	Standard	Suppression
Operator Sound Level (ISO 6396:2008)		72 dB(A)
Machine Sound Level (ISO 6395:2008)	112 dB(A)	110 dB(A)

- The operator sound pressure level was measured according to the test procedures and conditions specified in ISO 6396:2008. The measurement was conducted at 70 percent of the maximum engine cooling fan speed.
- The machine sound power level was measured according to the test ISO 6395:2008. The measurement was conducted at 70 percent of the maximum engine cooling fan speed.
- Hearing protection may be needed when operating with an open operator station and cab (when not properly maintained or doors/windows open) for extended periods or in a noisy environment.

Oils and Fluids

- Caterpillar factory fills with ethylene glycol coolants. Cat Diesel Engine Antifreeze/Coolant (DEAC) and Cat Extended Life Coolant (ELC) can be recycled. Consult your Cat dealer for more information.
- Cat Bio HYDO Advanced is an EU Ecolabel approved biodegradable hydraulic oil.
- Additional fluids are likely to be present, please consult the Operations and Maintenance Manual or the Application and Installation guide for complete fluid recommendations and maintenance intervals.

Features and Technology

- The following features and technology contribute to fuel savings and/or carbon reduction. Features may vary. Consult your Cat dealer for details.
 - Automatic engine and electrical system shutdown controls conserve fuel by reducing unnecessary idling
 - Throttle lock reduces fuel burn further by maintaining constant speed and also reduces operator fatigue
 - Advanced Productivity Electronic Control System (APECS) transmission controls delivers greater momentum on grades and saves fuel by carrying that momentum through the shift points
 - Extended maintenance intervals reduce fluid and filter consumption
 - Cat clean emissions module includes Diesel Particulate Filter (DPF), Diesel Oxidation Catalyst (DOC), and Selective Catalytic Reduction (SCR) technologies to reduce the engine's emissions



オフロード法2014年
基準適合



For more complete information on Cat products, dealer services, and industry solutions, visit us on the web at www.cat.com.

Materials and specifications are subject to change without notice. Featured machines in photos may include additional equipment. See your Cat dealer for available options.

© 2023 Caterpillar. All Rights Reserved. CAT, CATERPILLAR, LET'S DO THE WORK, their respective logos, Product Link, DEO-ULS, STIC, VIMS, XT, "Caterpillar Corporate Yellow", the "Power Edge" and Cat "Modern Hex" trade dress as well as corporate and product identity used herein, are trademarks of Caterpillar and may not be used without permission.

AEXQ3431-00 (1-2023)
Build number: 11A
(Global)

